

ENC06022 (60kW)

Fast DC Charger

ENC06022 is high efficient but thinner than common EV DC charger



- Multi-standard: CCS1, CCS2, CHAdeMO
- Network or standalone operation
- Optional RFID/App etc. for user identification and management
- Support smart charging and load balancing
- Efficiency > 95%, Power Factor ≥ 0.98
- Multiple protection to ensure users' safety
- 7 inches color touch screen with user friendly interface
- OCPP 1.6 JSON (Comply with latest OCPP protocol as SINO is the member of OCA)
- IK10& IP54, for indoor and outdoor applications
- Customization available

Applications

- EV bus station
- Highway gas/service station
- Parking garage
- Commercial fleet operators
- EV infrastructure operators and service providers
- EV dealer workshops



Power Specifications

Input Connection	3-Phase : 3P+N+PE
Input Voltage	400Vac \pm 10%
Frequency	50Hz or 60Hz
THDi	\leq 5%
Power Factor	\geq 0.98
Output Voltage	150Vdc - 1000Vdc
Max. Output Current	200A (250A Optional)
Rated Power	60kW

User Interface & Control

LCD Display	7" Color Touch Screen(12" Customization)
User Authentication	RFID(ISO/IEC 14443)(APP/ Credit Card Customization)
LED Indicator	Green/Blue/Red
Charger Connector	CCS2 (CCS1 / CHAdeMO Optional)
Number of Charging Interface	1 or 2
Energy Measuring	DC meter, with 1% accuracy

Communication

Backend	Ethernet (4G Optional)
Charging Protocol	ISO 15118 , DIN 70121
Backend Protocol	OCPP 1.6 J (OCPP2.x Coming soon)

Protection

Residual Current Device	Yes
Internal Fuse	Yes
Electrical Protection	Over/Under Voltage Protection, Over Current Protection, Short Circuit Protection, Over/Under Temperature Protection, Lightning Protection, Ground Fault, Surge Protection

Environmental

Operating Temperature	-30 $^{\circ}$ C - +50 $^{\circ}$ C
Storage Temperature	-40 $^{\circ}$ C - +75 $^{\circ}$ C
Operating Humidity	Max. 93% RH, Non-Condensing
Operating Altitude	\leq 2000m
IP, IK Level	IP54, IK10
Cooling Method	Fan Cooling

Mechanical

Product Dimension	700mm*240mm*1750mm(W*D*H)
Package Dimension	1100mm*750mm*1890mm(W*D*H)
Charging Cable Length	5m (Customizable)
Weight	220kg(Net) / 230kg(Gross)
Mounting	Free Standing

Certifications

Certificate	IEC62196-1, IEC62196-3, IEC 61851-1, IEC61851-23, IEC61851-24
Safety	CE

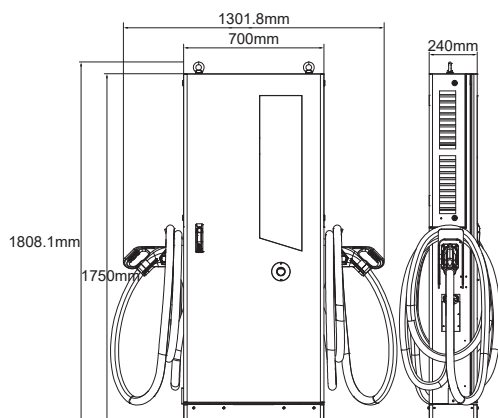
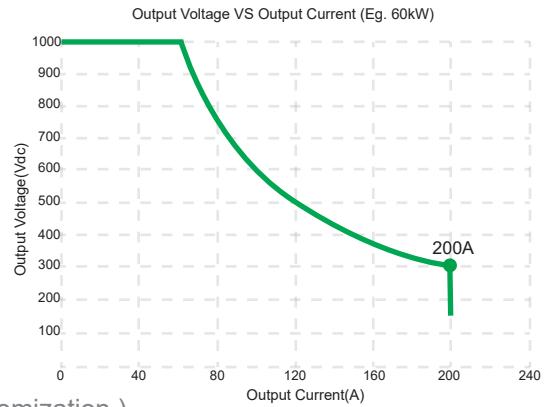

CTMS TECHNOLOGY CO., LTD.

19/8 Moo 18 Soi LamLukka 12
Khukhot, LamLukka Patumtani 12130 Thailand
WebSite : evcharger.ctms.co.th
Tel : 02-531-7111, 089-9897903